

654B (20 t)

Hydraulisk verkstadspress med flyttbart kolvhuvud**Hydraulic press with moveable piston**

Hydraulische Säulen- Werkstattpresse mit beweglichem Kolben

Presse hydraulique à colonne avec piston mobile

Prensa hidráulica de columna con pistón móvil



**Två-hastighets pump med både fotpedal och handpump • Automatisk retur av kolv • Förokromad kolvstång
• Tryckmätare • V-block ingår**

Double-speed hand pump • Overload safety-valve • Automatic return of the ram • Chromium plated rod • Pressure gauge
• V-blocks

Zweistufige Handpumpe • Überlastsicherung • Automat. Kolbenrücklauf • Verchromte Kolbenstange • Manometer • V-Prismen

Pompe manuelle double vitesse • Sécurité hydraulique en cas de surcharge • Retour automatique du piston • Tige chromée •
Manomètre • Jeu de prismes à V

Bomba de mano con dos velocidades • Seguridad hidráulica en caso de sobrecarga • Retorno automático del pistón • Vástago
cromado • Manómetro • Serie de prismas en V

Tekniska data

	651B	653B	654B	655B	656B	658B
A	1880	1880	1900	1900	1980	2200
B	620	690	770	770	890	980
C	600	600	600	600	600	700
D	500	550	610	610	710	780
E	150	150	150	150	150	165
F	1000	1000	1000	1000	1000	1000
G	160	160	160	160	160	160
H	820	900	950	950	1150	1250
L	300	340	380	380	450	500
kg	100	120	140	160	230	350

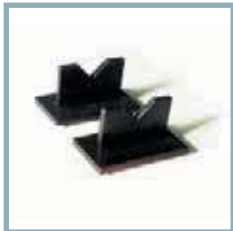
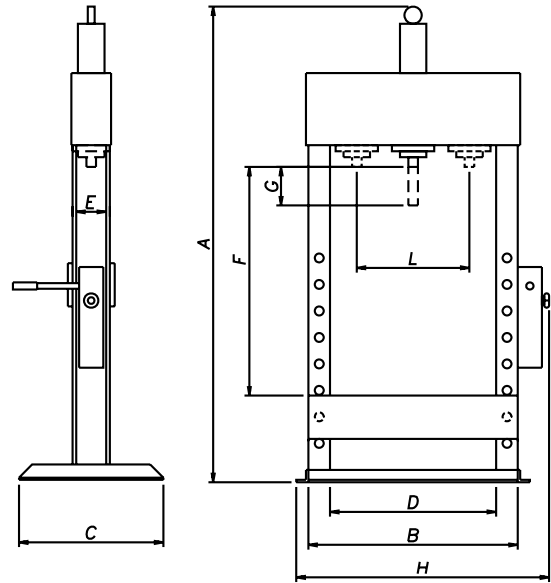

V-block (ingår)

Tillbehör



Pressplatta för dornsats



Dornsats